



SUNCOMBE
CIP & PROCESS ENGINEERS

PureCIP™ Systems



Suncombe Ltd, Jade House, Lockfield Avenue, Brimsdown, Enfield, Middlesex, EN37JY, United Kingdom

T +44(0)20-8443-3454 F +44(0)20-8443-3969 E info@suncombe.com W www.suncombe.com

www.suncombe.com

About Us

Suncombe Ltd supply Cleaning and hygienic processing technology for the BioPharma, Medical, Food and other critical hygiene industries. From CIP to PartsWashers, we are uniquely capable of offering you a complete washing and processing solution.

Formed in 1961, we have a tremendous amount of experience in-house and provide a high level of technical and engineering expertise. Our completed projects range from stand-alone systems to complete processing solutions. Our products are built to a high quality and encompass all relevant legislation, guidelines, testing, documentation, quality assurance and traceability requirements.

Suncombe PureCIP Range Details

The Suncombe PureCIP range has been developed over 45 years for providing a robust, reliable means of supplying repeatable, validateable, controllable CIP cleaning. Every unit is specifically designed for its particular application and is developed by Suncombe CIP engineers together with the client personnel to provide the optimum cleaning system and a simple validation trail. The range is based on standard modules with individual units custom designed and built - in-house - for your specific application. Manual or automatically operated, the systems are used for cleaning tanks, Vessels, Vats, Fermenters, Mixers, Processors, Pipework, Valves, Isolators, Glove Boxes, Mills, Coaters, Filters, Pumps, Dryers, Tumblers, Fillers and many other applications.

Duties

CIP Deliveries of 10 litres per minute to 250 litres per minute at pressures from 1 bar to 9 bar. Water temperatures up to 95°C. Detergent concentrations up to 5%.



CIP Liquid Storage

Incorporating a single or multiple 316L Stainless steel sanitary CIP storage vessels for storing, batching and delivering CIP fluids. Complete with control and safety instrumentation.

CIP Delivery

Incorporating a 316L Stainless steel variable speed pump the system can be tuned to your equipment, ensuring that the optimum CIP parameters are achieved every time whilst minimising liquid and energy usage and time.

Detergent Dosing

One to four liquid dosing systems, which can be incorporated within any recipe step at any concentration, complete with dosing safeguards including low detergent confirmation and detergent dosed volume confirmation, as well as pump priming facilities.

Automation

Suncombe offers four different control packages, CIPSuite1™ to CIPSuite4™, they all incorporate the optimum control for operation, providing a simple to use interface which incorporates advanced facilities.

Validation/ Documentation

The lifecycle approach is adopted (DQ, FAT, SAT, IQ & OQ) with validation being key to every stage of the development process, including Factory Acceptance Testing (FAT), SAT and Qualification.

Lean Technology

Adopting LEAN principles, all Suncombe products are developed to ensure they minimise utilities and time, whilst ensuring the safety of the operators and the efficiency of the cleaning. Utilising innovative fluid handling techniques, they incorporate a combination of traditional and new technologies to provide an environmentally friendly, low water and energy usage washing facility that is safe and ergonomic for the operators.

Key Features

- 316L Stainless steel wetted parts .
- Sloping design and smooth, crevice-free construction
- EPDM, PTFE FDA-approved elastomers and tri-clamp connections
- Enclosed head orbital welding to EN287/15614
- 316/304 stainless steel non-wetted parts
- 50—2000 litre storage vessels can be incorporated with double wall insulated construction to reduce electricity consumption and heat loss
- Atmospheric vents or heated vent filter options
- BioPharma Diaphragm valves
- Certified surface finishes to 0.4 ra and optionally electropolished
- Large hygienic variable speed delivery pump
- BioPharma instrumentation
- Fully self-draining including pump housing
- Steam heated using double plate or shell and tube heat exchangers
- One to four detergent dosing systems including dosing confirmation
- Fully adjustable cycle parameters including temperatures, pressures and times
- Conductivity controllers for detergent concentration and pure water.
- CIPSuite™ Control Systems with a colour graphic operator interface for visualisation
- Password control
- Up to 100 Fully configurable recipes
- In built troubleshooting and diagnostic ability
- USB port for connections to desktop printer
- Desktop printer for printouts of operation
- Easy maintenance
- Final rinse recirculated or non-recirculated to eliminate possibility of cross-contamination between rinses.
- Can be fitted with stainless steel or clear covers
- ATEX versions available for solvent use and/or aqueous use in zoned areas

Support

The Suncombe Technical Support and Customer Care departments' obligation is to provide total customer support. This support starts at the proposal stage, continues throughout the contract and thereafter. A personal customer care agent will be assigned to you at quotation stage and will support you throughout. The department currently supports all of our clients over the last 50 years. Support includes advise and surveys, installation and commissioning, User training, call-out repairs and service contracts for preventative maintenance.

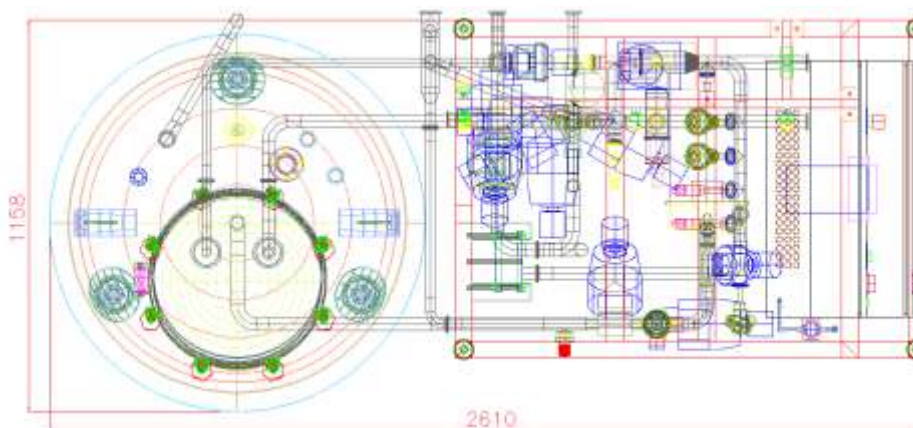

Automation

CIPSuite#2™ - Automatic control system with 100 fully configurable recipes, time changeable recipes, I/O faceplates, Mimic diagrams, Hard wired interfaces, Printer, Repeatable automatic cycles, User control with passwords, In built troubleshooting and diagnostic ability.

Mimic

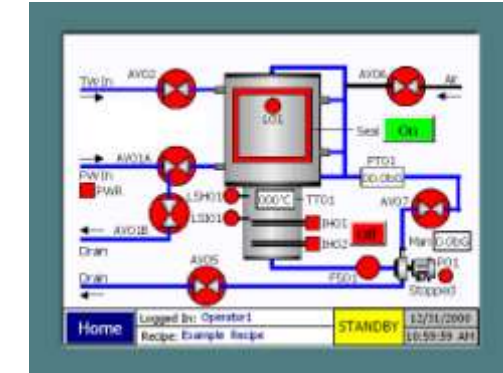

Recipe Setup



CIPSuite#3™ - Automatic control system with 100 fully configurable recipes, time changeable recipes, I/O faceplates, Mimic diagrams, profibus, ethernet and hard wired interfaces, Printer, Datalogger, Repeatable automatic cycles, User control with passwords, In built troubleshooting and diagnostic ability.

Mimic

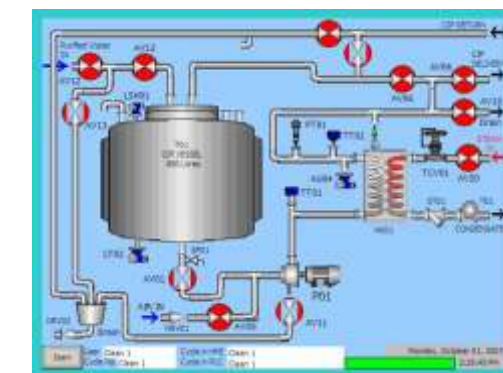

Recipe Setup

